

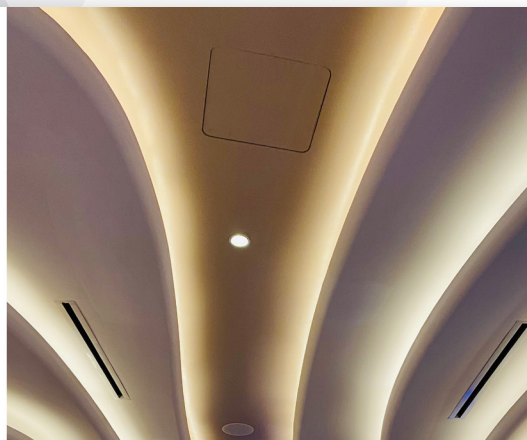

STEALTH™

A FORMGLAS® | WIND-LOCK® STRATEGIC ALLIANCE



#1 GFRG HIDDEN ACCESS PANELS

WIND-LOCK™

Stealth GFRG Access Panels

Clean. Simple. Hidden.

Stealth Access Panels are Glass Fiber Reinforced Gypsum (GFRG) ceiling and wall access panels that are designed to blend seamlessly into any drywall ceiling or wall where periodic access is required.

The panels consist of a surround frame with pre-drilled/spotted fastener holes and a drop-in door (for ceiling access) or a hinged door with a latching mechanism (for wall applications).

The hinged models offer 3 different styles of latching mechanisms (Lock-Latch, Touch Latch, or Keyless/Cam-Latch) depending on the ease of access desired.

Ideal for use in both New Construction and Retrofit Construction projects, Stealth Access Panels are available in Commercial or Residential models for Interior projects in a wide range of stock sizes as well as a host of special-order custom size configurations.

Residential models incorporate an energy-saving gasket seal that keeps air from passing through and keeps attic temperatures from infiltrating the living space.

Wind-lock also offers Exterior (FRP) models, talk to your Sales Rep for more information.

If you think Stealth Access Panels could benefit your next project, please contact us today at 800-872-5625 or email us at info@wind-lock.com.



Features & Benefits:

- Tapered Edge Frame
- Easily Textured & Paintable
- Lightweight
- Blends with Surrounding Drywall
- No Shrinkage
- No Cracking After Install
- New Construction or Retrofit Jobs
- Reduces Labor Costs

Commercial

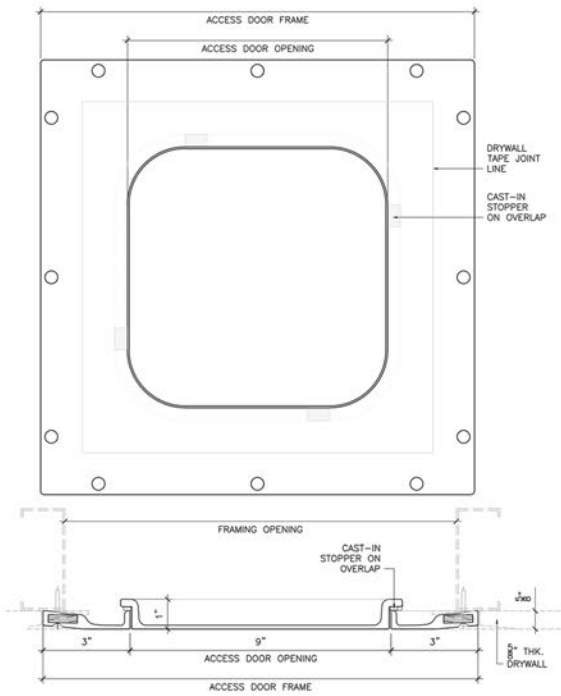

Residential

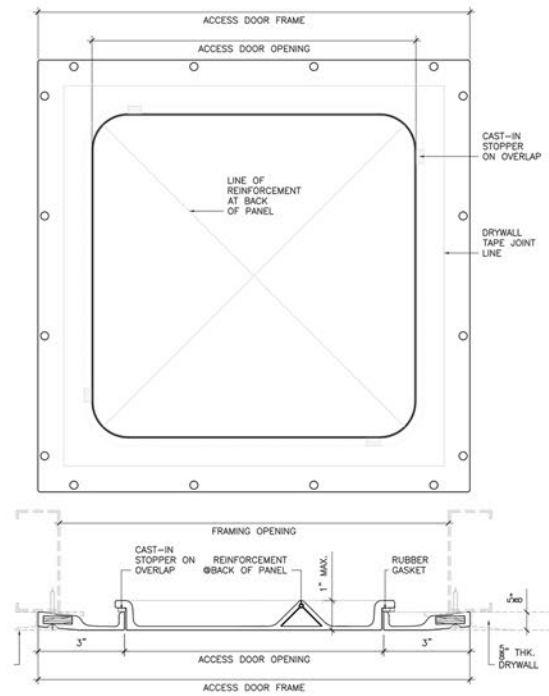

Job Name: _____

Company Name: _____

Main Contact for Project: _____

Date Panels Are Needed: _____

Estimated Duration of Job: _____

Approved By: _____

COMMERCIAL PANELS

New Part Code	Door/Access Opening (in)	Rough/Frame Opening (in)	Description	Door/Access Corner Style	Stock Status/Notes	QTY to Order
AP-DR0909	9x9	15x15	Standard, Drop in	Radius	Standard Stock	
AP-DR1212	12x12	18x18	Standard, Drop in	Radius	Standard Stock	
AP-DR1616	16x16	22x22	Standard, Drop in	Radius	Standard Stock	
AP-DR1818	18x18	24x24	Standard, Drop in	Radius	Standard Stock	
AP-DR2424	24x24	30x30	Standard, Drop in	Radius	Standard Stock	
AP-DR3636	36x36	42x42	Standard, Drop in	Radius	Standard Stock (Supplies Limited)	
AP-DS0909	9x9	15x15	Standard, Drop in	Square	Special Order Item	
AP-DS1212	12x12	18x18	Standard, Drop in	Square	Special Order Item	
AP-DS1616	16x16	22x22	Standard, Drop in	Square	Special Order Item	
AP-DS1818	18x18	24x24	Standard, Drop in	Square	Special Order Item	
AP-DS2424	24x24	30x30	Standard, Drop in	Square	Special Order Item	

RESIDENTIAL PANELS

Wind-lock Part Code	Door/Access Opening (in)	Rough/Frame Opening (in)	Description	Door/Access Corner Style	Stock Status/Notes	QTY to Order
AP-DR2230	21.5x30	24x36	Residential (includes gasket)	Radius	Standard Stock Item	
AP-DR3030	30x30	36x36	Residential (includes gasket)	Radius	Standard Stock Item	

****Additional Cut Sheets with the specific panel demensions listed above available upon request****

****For LEED information please contact your Wind-lock Sales Representative****

Key-Latch

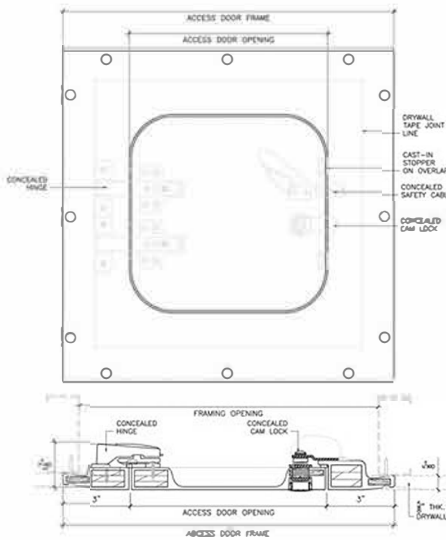

Touch Latch

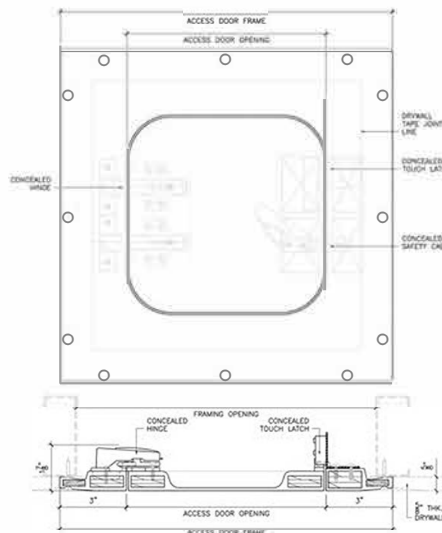

Keyless-Latch

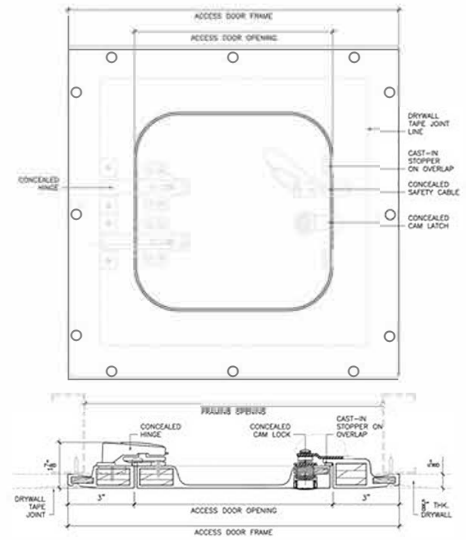

Job Name: _____

Company Name: _____

Main Contact for Project: _____

Date Panels Are Needed: _____

Estimated Duration of Job: _____

Approved By: _____

HINGED: KEY-LATCH

New Part Code	Door/Access Opening (inches)	Rough/Frame Opening (inches)	Description	Door/Access Corner Style	Stock Status/Notes	QTY to Order
AP-HRK0909	9x9	15x15	Standard, Hinged	Radius	Standard Stock	
AP-HRK1212	12x12	18x18	Standard, Hinged	Radius	Standard Stock	
AP-HRK1616	16x16	22x22	Standard, Hinged	Radius	Standard Stock	
AP-HRK1818	18x18	24x24	Standard, Hinged	Radius	Standard Stock	
AP-HRK2424	24x24	30x30	Standard, Hinged	Radius	Standard Stock	

HINGED: TOUCH LATCH

New Part Code	Door/Access Opening (inches)	Rough/Frame Opening (inches)	Description	Door/Access Corner Style	Stock Status/Notes	QTY to Order
AP-HRT0909	9x9	15x15	Standard, Hinged	Radius	Special Order Item	
AP-HRT1212	12x12	18x18	Standard, Hinged	Radius	Special Order Item	
AP-HRT1616	16x16	22x22	Standard, Hinged	Radius	Special Order Item	
AP-HRT1818	18x18	24x24	Standard, Hinged	Radius	Special Order Item	
AP-HRT2424	24x24	30x30	Standard, Hinged	Radius	Special Order Item	

HINGED: KEYLESS-LATCH (No Lock)

New Part Code	Door/Access Opening (inches)	Rough/Frame Opening (inches)	Description	Door/Access Corner Style	Stock Status/Notes	QTY to Order
AP-HRC0909	9x9	15x15	Standard, Hinged	Radius	Special Order Item	
AP-HRC1212	12x12	18x18	Standard, Hinged	Radius	Special Order Item	
AP-HRC1616	16x16	22x22	Standard, Hinged	Radius	Special Order Item	
AP-HRC1818	18x18	24x24	Standard, Hinged	Radius	Special Order Item	
AP-HRC2424	24x24	30x30	Standard, Hinged	Radius	Special Order Item	

****Additional Cut Sheets with the specific panel dimensions listed above available upon request****

****For LEED information please contact your Wind-lock Sales Representative****

Touch Latch

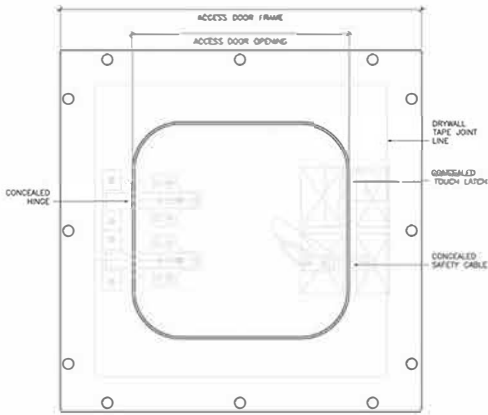

Key-Latch

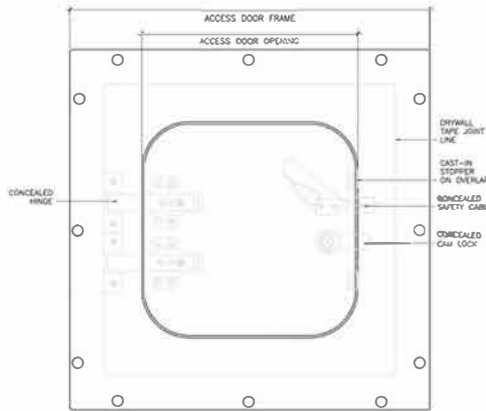

Keyless-Latch

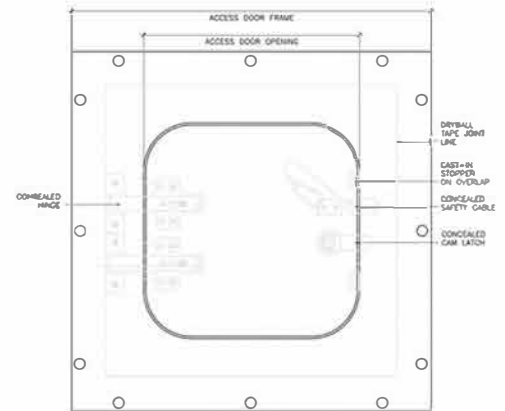

Job Name: _____

Company Name: _____

Main Contact for Project: _____

Date Panels Are Needed: _____

Estimated Duration of Job: _____

Approved By: _____

****PLEASE NOTE: LEAD-TIME & PRICING SUBJECT TO MOLD CREATION (IF NECESSARY) AND CAN VARY BY SIZE, STYLE, QUANTITY AND DESIRED DELIVERY DESTINATION****

CUSTOM DROP-IN/CEILING PANELS

Door/Access Opening (inches, AxB)	Door/Access Corner Style (Radius or Square)	QTY to Order

CUSTOM HINGED PANELS: TOUCH LATCH

Door/Access Opening (inches, AxB)	Door/Access Corner Style (Radius or Square)	QTY to Order

CUSTOM HINGED PANELS: KEY-LATCH

Door/Access Opening (inches, AxB)	Door/Access Corner Style (Radius or Square)	QTY to Order

CUSTOM HINGED PANELS: KEYLESS-LATCH (No Lock)

Door/Access Opening (inches, AxB)	Door/Access Corner Style (Radius or Square)	QTY to Order

****Custom Molds are good for up to 6 months from the date they are produced; any mold older than 6 months may be subject to a second charge for the creation of a new mold****

****Additional Cut Sheets with the specific panel dimensions listed above available upon request****

****For LEED information please contact your Wind-lock Sales Representative****

Installing the Stealth Access Panel Frame:



1. Frame out location of the panel.



2. Affix panel frame by screwing it into ceiling frame using pre-marked divots.



3. Hang drywall around the panel frame.

Finishing After Drywall Installation:



1. Apply drywall mud base, covering seams and screws.



2. Apply drywall tape, also covering seams and screws.



3. Smooth drywall tape and compound with a taping knife.



4. Apply second layer of mud and smooth with a taping knife.



5. Once dry, smooth tape joints and install your panel door.



Specification for Glass Fiber Reinforced Gypsum (GFRG) STEALTH Access Panels by Wind-lock (For Interior Applications)

1. General

1.1 Summary

A. This section includes furnishing all materials, labor, equipment, and related services necessary to supply and install molded glass fiber reinforced gypsum (GRG) parts as indicated in the contract documents, and in compliance with applicable codes.

1.2 Related Sections

- A. Section 06 10 00 Rough Carpentry - for blocking, nailers, shims and carpentry supporting glass fiber reinforced gypsum fabrications.
- B. Section 09 22 00 Supports for Plaster and Gypsum Board - for support, blocking, and bracing supporting glass fiber reinforced gypsum fabrications.
- C. Section 09 90 00 Painting and Coating

1.3 References

- A. ASTM International (ASTM)
 - 1. C1381 Standard Specification for Molded Glass Fiber Reinforced Gypsum Parts.
 - 2. C1467 Standard Specification for the Installation of Molded Glass Fiber Reinforced Gypsum Parts.
 - 3. C1355 Standard Specification of Glass Fiber Reinforced Gypsum Composites
 - 4. C754 Specification for Installation of Steel Framing Members to Receive Screw-Attached Gypsum Panel Products.
 - 5. C1007 Specification for Installation of Load Bearing (Transverse and Axial) Steel Studs and Related Accessories.
 - 6. C840 Specification for Application and Finishing of Gypsum Board

1.4 Submittals

- A. Product Data: Submit product data sheets for each specified product, including dimensions, finishes, storage and handling requirements and recommendations and installation recommendations.
- B. Samples: 6 inches (150mm) square, representing actual product, color and patterns available upon request.
- C. Shop Drawings: Submit drawings for approval showing plans, sections, details, joint treatment, reinforcing, fastening devices and the relation of the GRG parts to the surrounding construction.

1.5 Quality Assurance

- A. GRG Parts and Installation to conform to ASTM Standards governing Molded Glass Fiber Reinforced Gypsum Parts, namely: C1355; C1381; and, C1467 including physical properties and tolerances. See 1.3 References.
- B. Manufacturer Qualifications: Manufacturer shall have a minimum of 5 years of experience having successfully supplied GRG parts for other projects similar in scope and complexity for the work of this Contract.
- C. Installer Qualifications: Installer shall have a minimum of 5 years of experience having successfully installed GRG parts for other projects similar in scope and complexity for the work of this Contract.
- D. The Alpha gypsum cement used to make the GRG parts is to be mined and processed in the USA with a purity of not less than 90% in accordance to ASTM C1355. Provide a Manufacturer's Certification of Raw Materials.
- E. Substrates to accept GRG parts shall be installed straight and true within 1/8 in. in 8 linear ft. (3mm in 2500mm) in accordance to ASTM C1467 and shall be free of obstructions and interference that prohibits the correct alignment and attachment of the GRG parts.
- F. The gypsum drywall contractor shall install and tape the work under this section and will be responsible for coordinating the installation with gypsum drywall work and other trades.

1.6 Delivery, Storage and Handling

A. GRG parts shall be kept clean and dry and stored to prevent distortion, warping, and other physical damage in accordance with the manufacturer's recommendations.

1.7 Project Conditions

A. Environmental Limitations: Do not deliver or install GRG parts until building is enclosed and weatherproof, wet work is complete, and the HVAC system maintains temperature and humidity at normal occupancy levels.

B. Acclimatize GRG parts for a minimum of 48 hours to the ambient temperature and humidity levels of spaces in which they are to be installed.

2. Products

2.1 Manufacturers

Wind-lock
2692 Leisz's Bridge Rd
Leesport, PA 19533
800-872-5625
www.wind-lock.com

2.2 Substitutions

A. Not permitted.

B. Request for substitutions will be considered on accordance with provisions of Section 01600.

2.3 Glass Fiber Reinforced Gypsum (GRG) Parts

A. Fabrications: Molded GRG parts made in accordance with samples, shop drawings and with ASTM C1381 Standard for Molded Glass Fiber Reinforced Gypsum Parts.

B. Materials: Molded GRG parts to be made in accordance with ASTM C1355 Standard for Glass Fiber Reinforced Gypsum Composites.

C. Embedment: GRG parts to have typical embedment and reinforcement of galvanized steel or wood, if required, for the purposes of suspension, attachment and stiffness.

D. Molded GRG units to be ready for primer for typical flat paint finishes.

E. GRG parts subject to critical lighting or scheduled to receive semi-gloss decoration shall be prepared as a Level 5 finish which may require skim coats, filling, and sanding to hide imperfections inherent in GRG, in accordance to ASTM Standards C840 and C1467.

2.4 Physical Properties

A. Molded Glass Fiber Reinforced Gypsum Parts meet the following mechanical properties including those required in ASTM Standards C1381 & C1355:

- (1) Glass Content: not less than 5 percent by weight
- (2) Density: 103 to 112 pcf
- (3) Shell (Part) Thickness: not less than 3/16"
- (4) Control Thickness: not less than 5/16"
- (5) Dimensional: overall in all directions +/- 1/8"
- (6) Straightness: +/- 1/8" in 8 ft
- (7) Warpage/Bowing: +/- 1/16" per ft
- (8) Draft Angle: 3 degrees minimum on returns, setbacks, reveals and grooves
- (9) Flexural Yield Strength: not less than 1200 psi (ASTM C947)
- (10) Flexural Ultimate Strength: not less than 2500 psi (ASTM C947)
- (11) Impact Resistance: not less than 3 ft-lb (ASTM D256)
- (12) Hardness: not less than 50 Barcol (ASTM D2583)
- (13) Coefficient of Linear Thermal Expansion: not more than 11.1×10^{-6} in/in °F (ASTM D696)
- (14) Humidified Deflection: not more than 1/8" (3 mm) (ASTM C473)
- (15) Flammability: Flame Spread & Smoke Development Index of 0 (ASTM E84)
- (16) Behavior at 750°C: Pass (ASTM E136)
- (17) Nail Pull Resistance: not less than 110 lbf (ASTM C473)

3. Execution

3.1 Examination

- A. Site Conditions: Verify the conditions for compliance with the requirements including environmental conditions, installation tolerances and other conditions affecting the installation and performance of GRG parts. Any unsatisfactory conditions to be corrected prior to installation.
- B. Field Dimensions: Field dimensions are to be verified including those not shown on the drawings. Any discrepancies are to be brought to the attention of the Architect with resolutions to the discrepancies to be mutually agreed upon by all parties involved. Details of any changes required must be incorporated into the manufacturer's shop drawings prior to commencing the manufacture of the GRG parts.

3.2 Preparation

- A. Substrate: Substrates to accept GRG parts, provided by others, shall be installed straight and true within 1/8 in. in 8 ft. (3mm in 2500mm) and shall be free of obstructions and interference that prohibits correct attachment of GRG parts.
- B. Metal framing members, provided by others, shall be of the proper size and design for the intended use and shall be sufficient to properly support the installed GRG parts. Metal framing members shall be installed in accordance with ASTM Standards C754 or C1007 as required.
- C. Ensure clean surfaces prior to installation.

3.3 Installation

- A. Comply with ASTM C1467 Standard for the Installation of Molded Glass Fiber Reinforced Gypsum Parts.
- B. It is the Installer's responsibility to verify scope and to order the correct quantities of parts (including a waste allowance).
- C. Supply and install all shims and brackets required for work in this section and to ensure a solid and secure installation of GRG parts.
- D. Position GRG parts carefully into place and align with adjacent parts and materials in accordance to the drawings. Attach GRG parts to substrates and framing with fastening devices as specified by the GRG manufacturer. Use concealed shims as required and countersink screws below the surrounding surface.
- E. Where GRG parts are suspended, use the suspension points indicated on the shop drawings as a minimum requirement and use additional support(s) if required.
- F. Install control joints between GRG parts as indicated and as required by the manufacturer.
- G. Use joint-treatment materials to finish GRG parts and assemblies to produce surfaces ready to receive primers and paint finishes as detailed. Note: Unfinished GRG parts may exhibit slight imperfections, normally hidden by a textured finished. To obtain satisfactory results with smooth finishes, filling and sanding will be required to hide imperfections inherent in GRG.

3.4 Protection

- A. Protect installed products until completion of project.
- B. Touch-up, repair or replace damaged products before substantial completion.

END OF SECTION

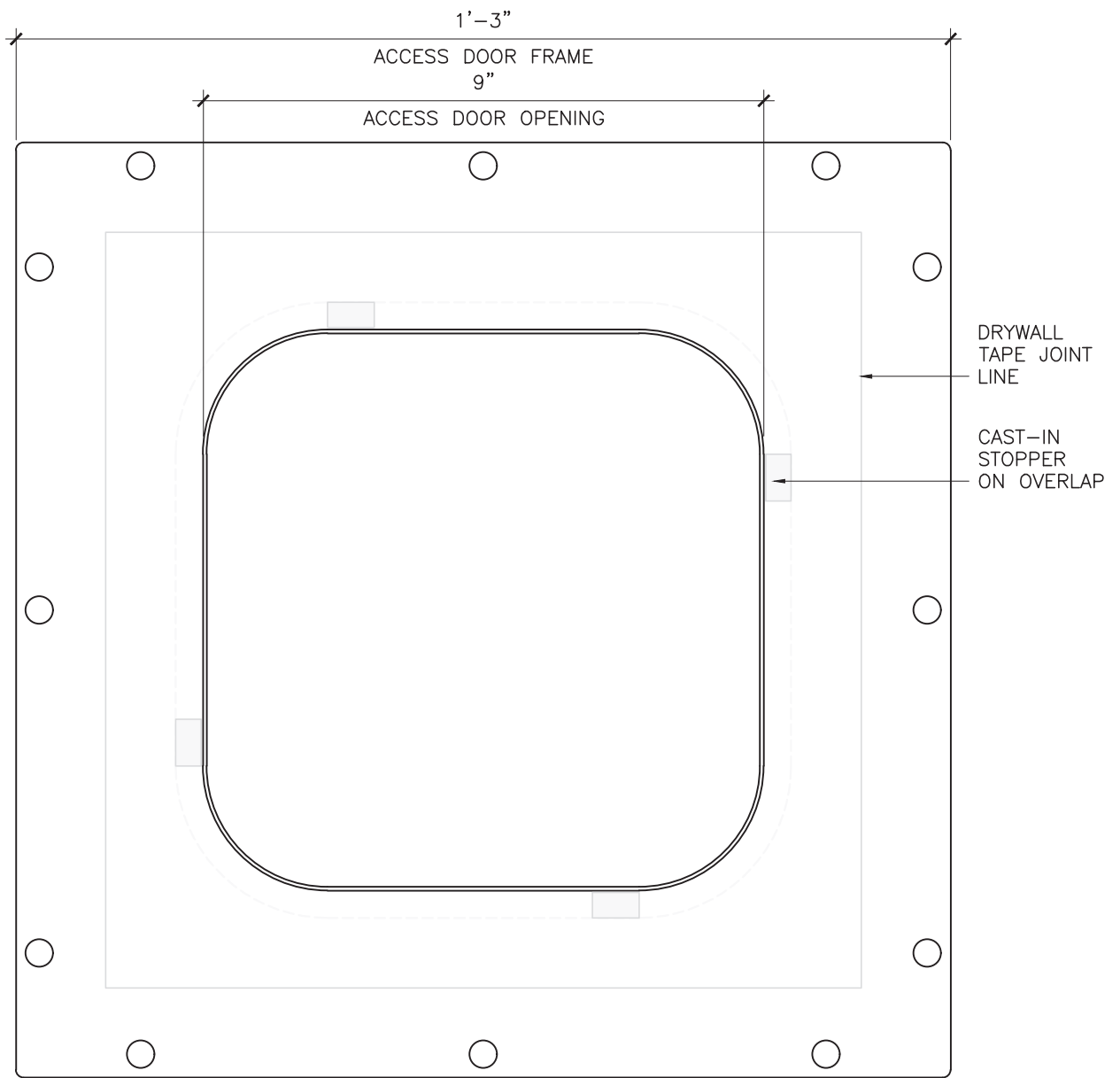

**FOR MORE INFORMATION REFER TO STEALTH
SHOP DRAWING AP-DR0909**

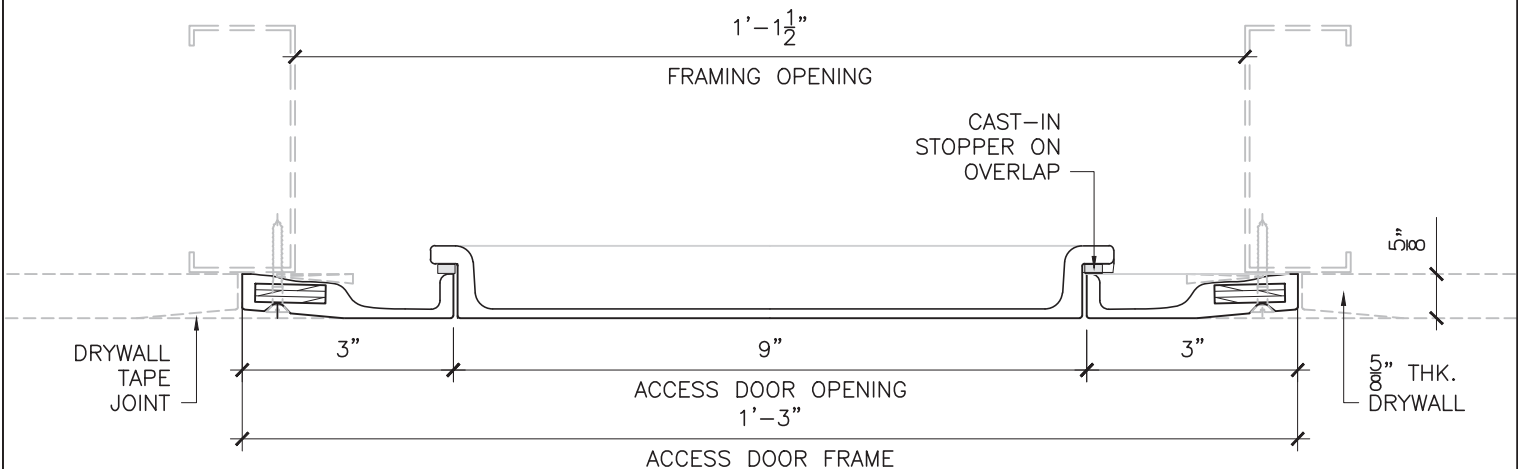

HEAD OFFICE:
1055 LEISCZ'S BRIDGE RD. TOLL: 1(800) 872.5625
LEESPORT, PA 19533 WWW.STEALTHPANELS.COM

SIMPLIFIED PLAN & SECTION
GFRG ACCESS PANEL
DROP IN
RADIUS DOOR CORNERS

DATE: OCT 09/18

SCALE: NTS

DWN.: ML

CHK.:

DWG: **AP-DR0909**

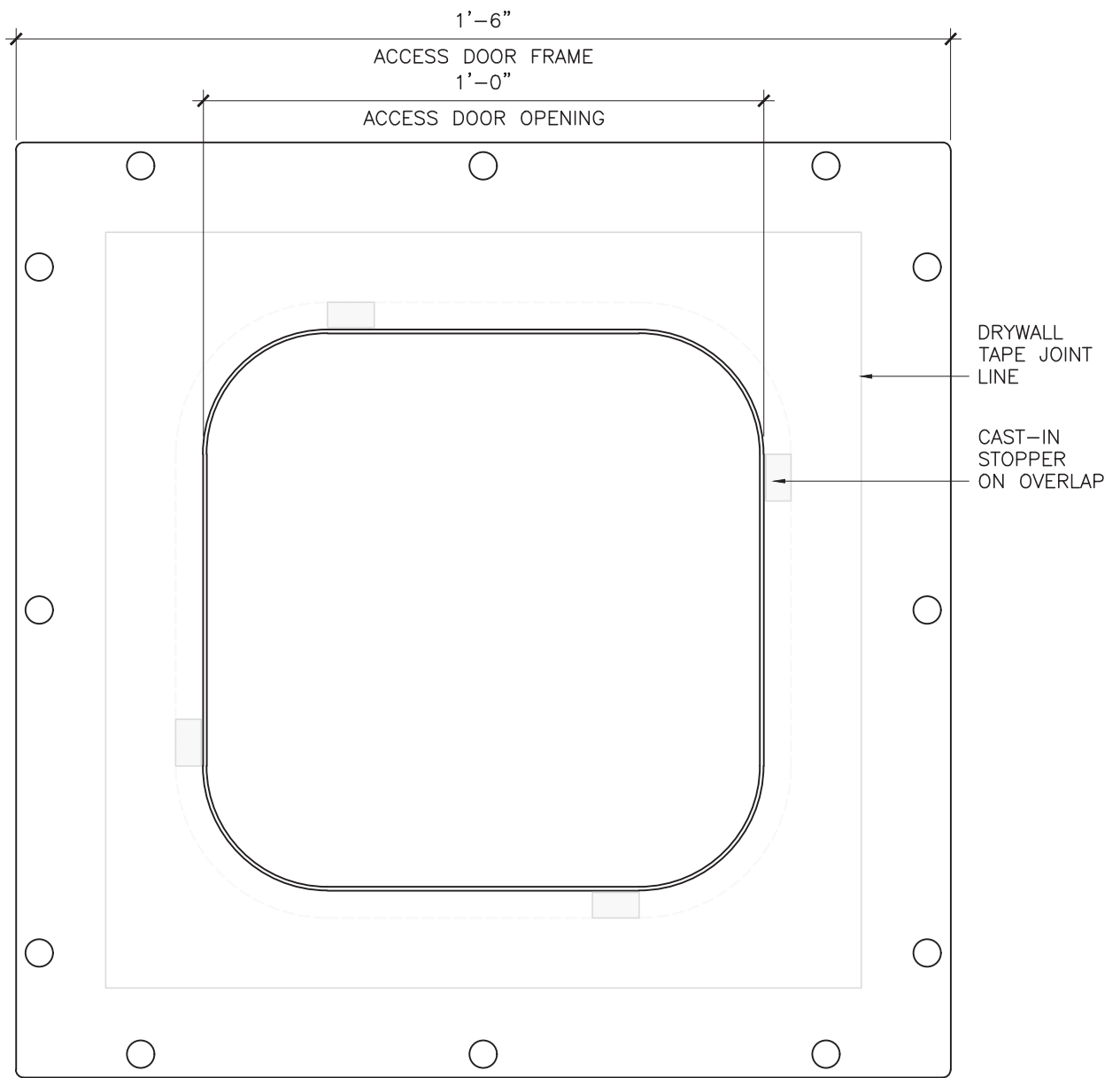

**FOR MORE INFORMATION REFER TO STEALTH
SHOP DRAWING AP-DR1212**

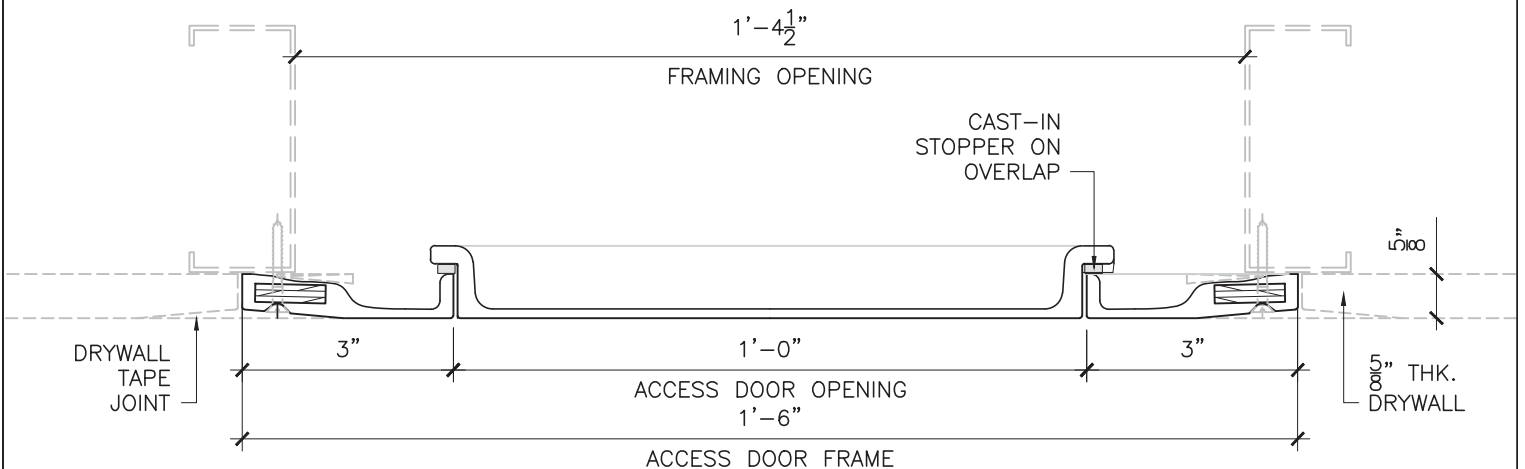

HEAD OFFICE:
1055 LEISCZ'S BRIDGE RD. TOLL: 1(800) 872.5625
LEESPORT, PA 19533 WWW.STEALTHPANELS.COM

SIMPLIFIED PLAN & SECTION
GFRG ACCESS PANEL
DROP IN
RADIUS DOOR CORNERS

DATE: OCT 09/18

SCALE: NTS

DWN.: ML

CHK.:

DWG: **AP-DR1212**

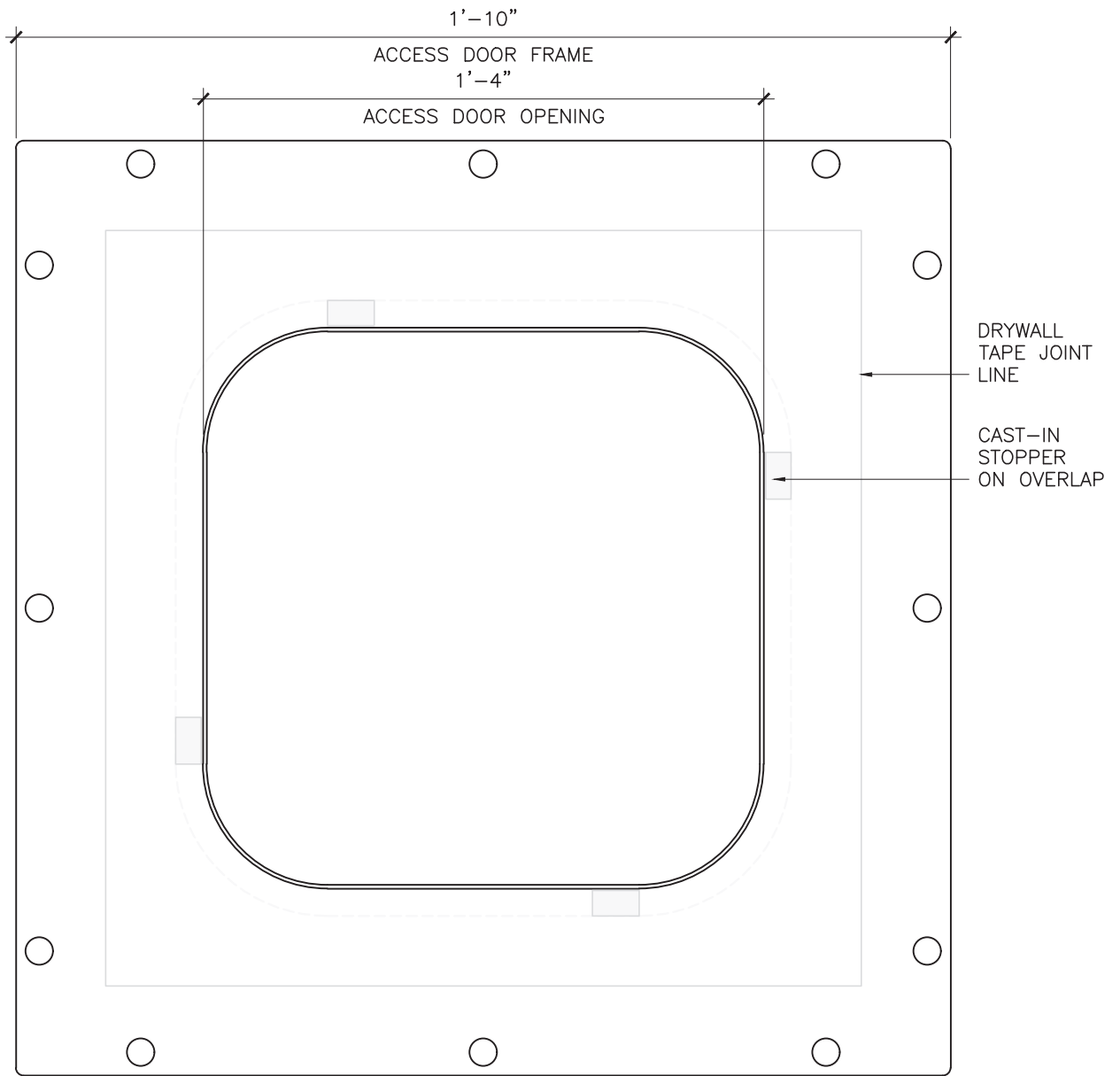

**FOR MORE INFORMATION REFER TO STEALTH
SHOP DRAWING AP-DR1616**

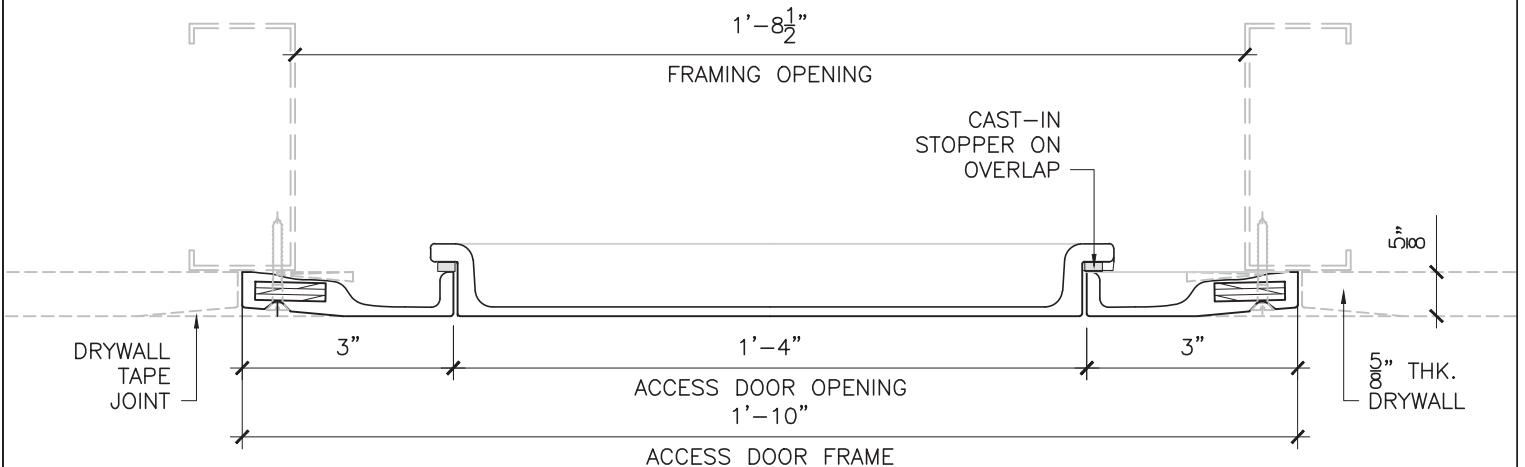

HEAD OFFICE:
1055 LEISCZ'S BRIDGE RD. TOLL: 1(800) 872.5625
LEESPORT, PA 19533 WWW.STEALTHPANELS.COM

SIMPLIFIED PLAN & SECTION
GFRG ACCESS PANEL
DROP IN
RADIUS DOOR CORNERS

DATE: OCT 09/18

SCALE: NTS

DWN.: ML

CHK.:

DWG: **AP-DR1616**

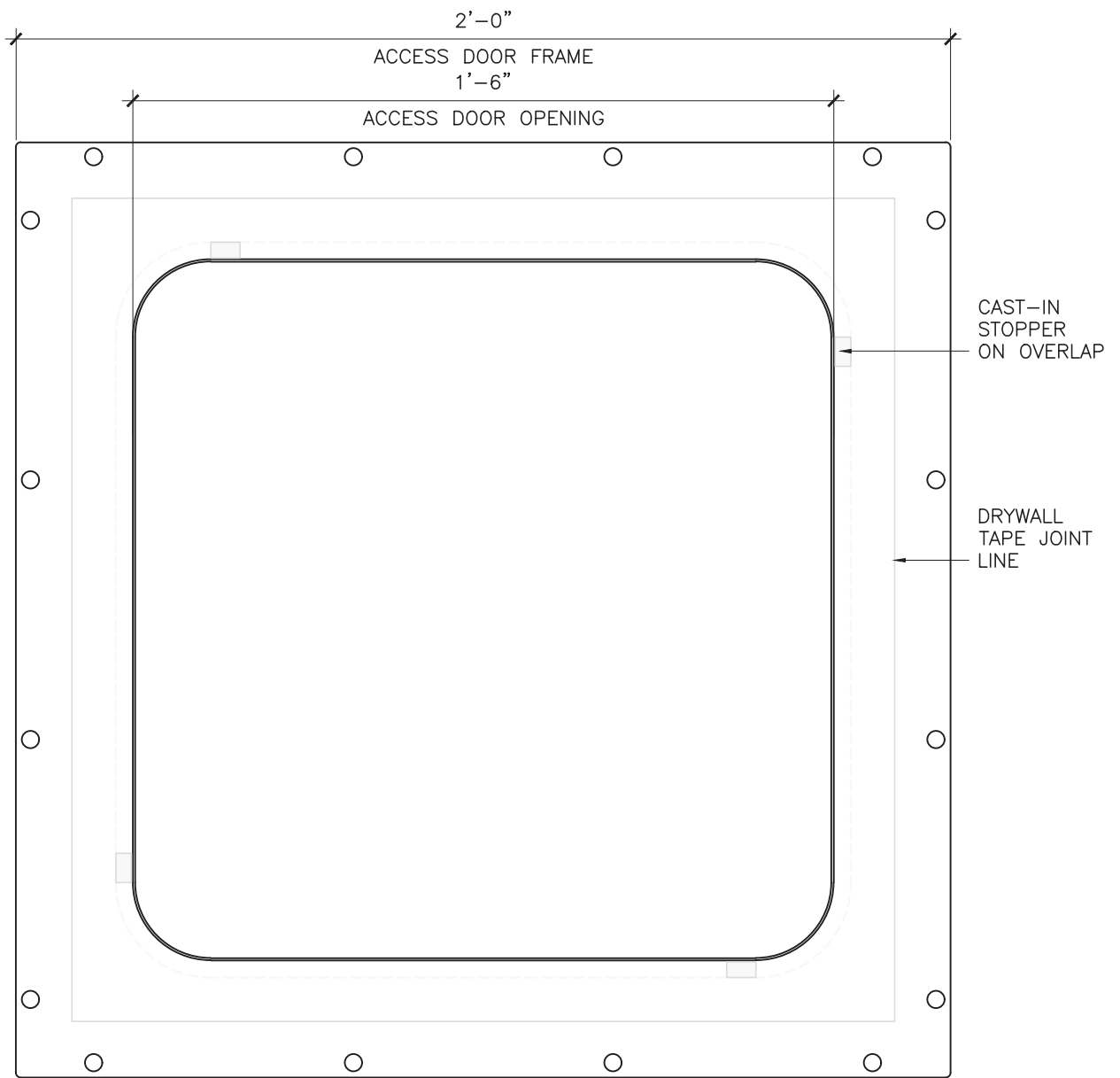

**FOR MORE INFORMATION REFER TO STEALTH
SHOP DRAWING AP-DR1818**

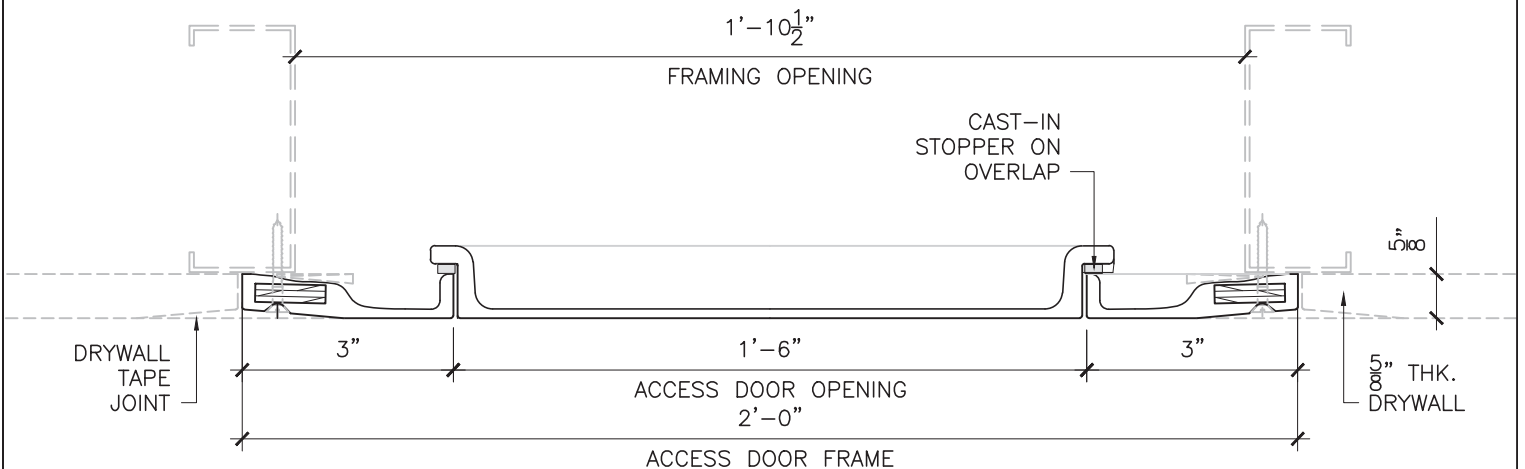

HEAD OFFICE:
1055 LEISCZ'S BRIDGE RD. TOLL: 1(800) 872.5625
LEESPORT, PA 19533 WWW.STEALTHPANELS.COM

SIMPLIFIED PLAN & SECTION
GFRG ACCESS PANEL
DROP IN
RADIUS DOOR CORNERS

DATE: OCT 09/18

SCALE: NTS

DWN.: ML

CHK.:

DWG: **AP-DR1818**

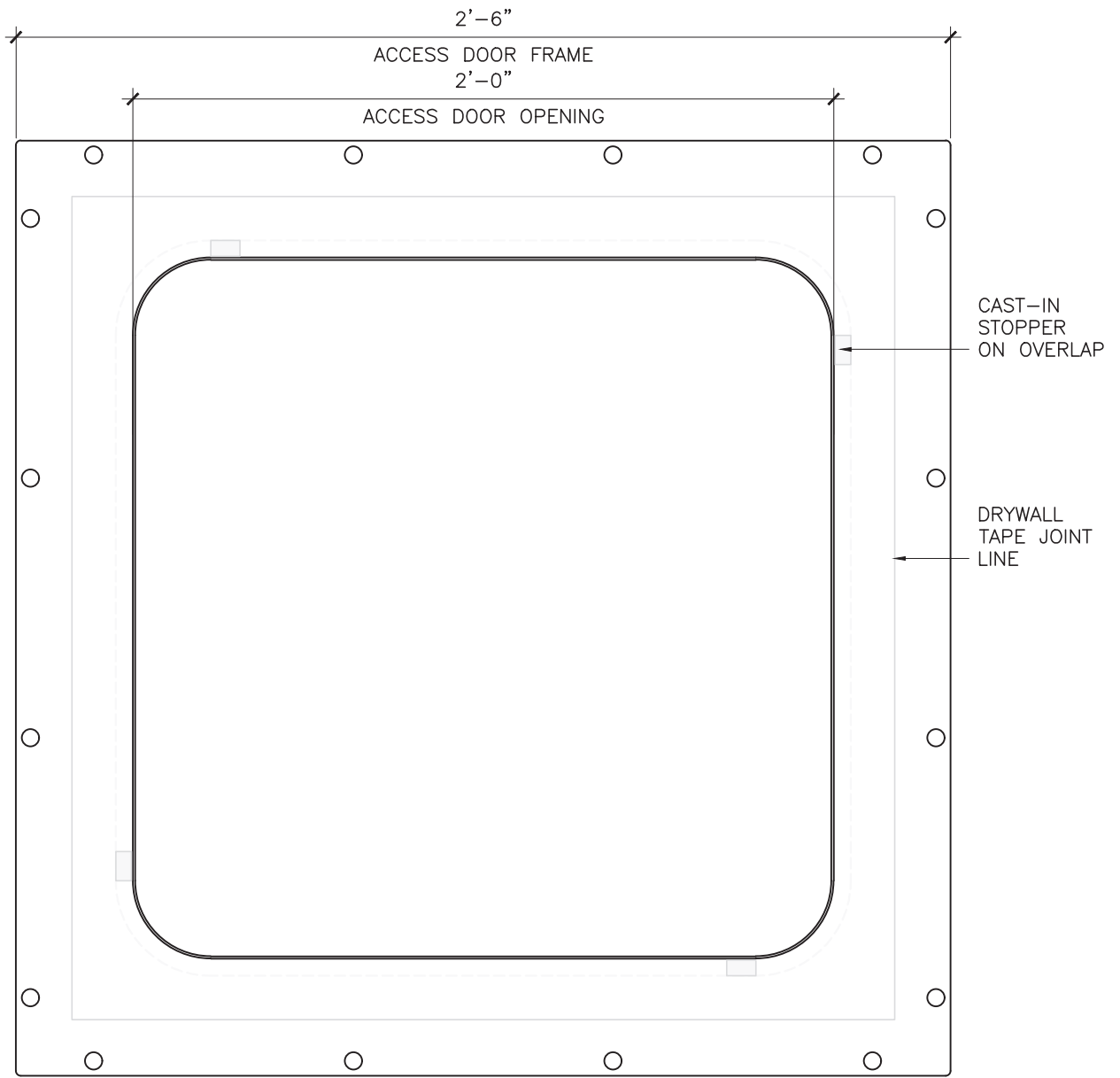

**FOR MORE INFORMATION REFER TO STEALTH
SHOP DRAWING AP-DR2424**

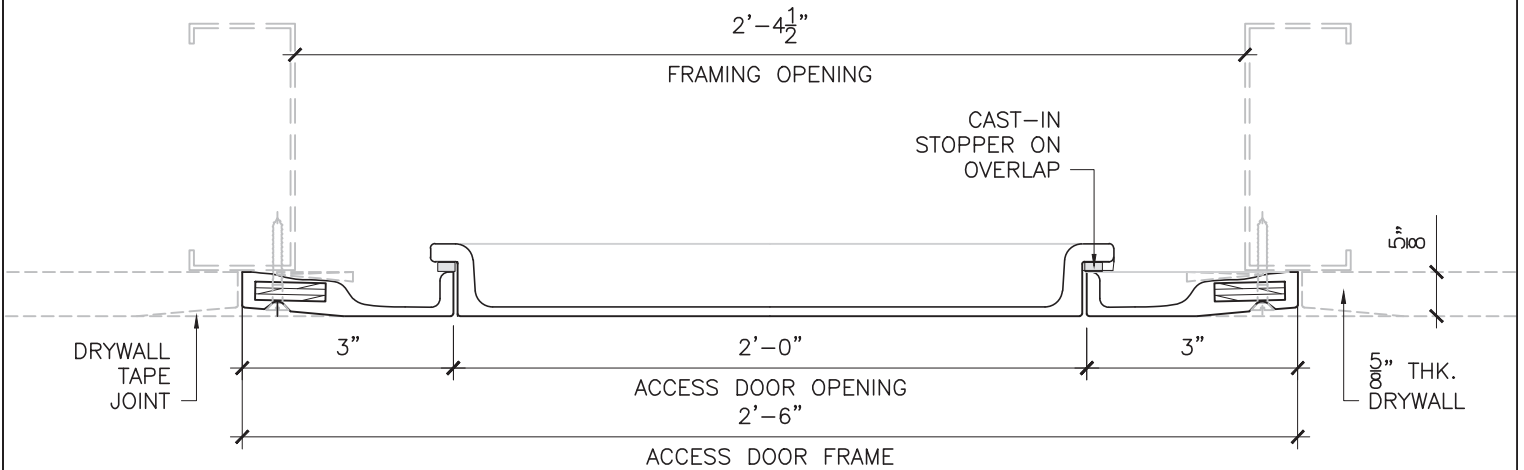

HEAD OFFICE:
1055 LEISCZ'S BRIDGE RD. TOLL: 1(800) 872.5625
LEESPORT, PA 19533 WWW.STEALTHPANELS.COM

SIMPLIFIED PLAN & SECTION
GFRG ACCESS PANEL
DROP IN
RADIUS DOOR CORNERS

DATE: OCT 09/18

SCALE: NTS

DWN.: ML

CHK.:

DWG: **AP-DR2424**

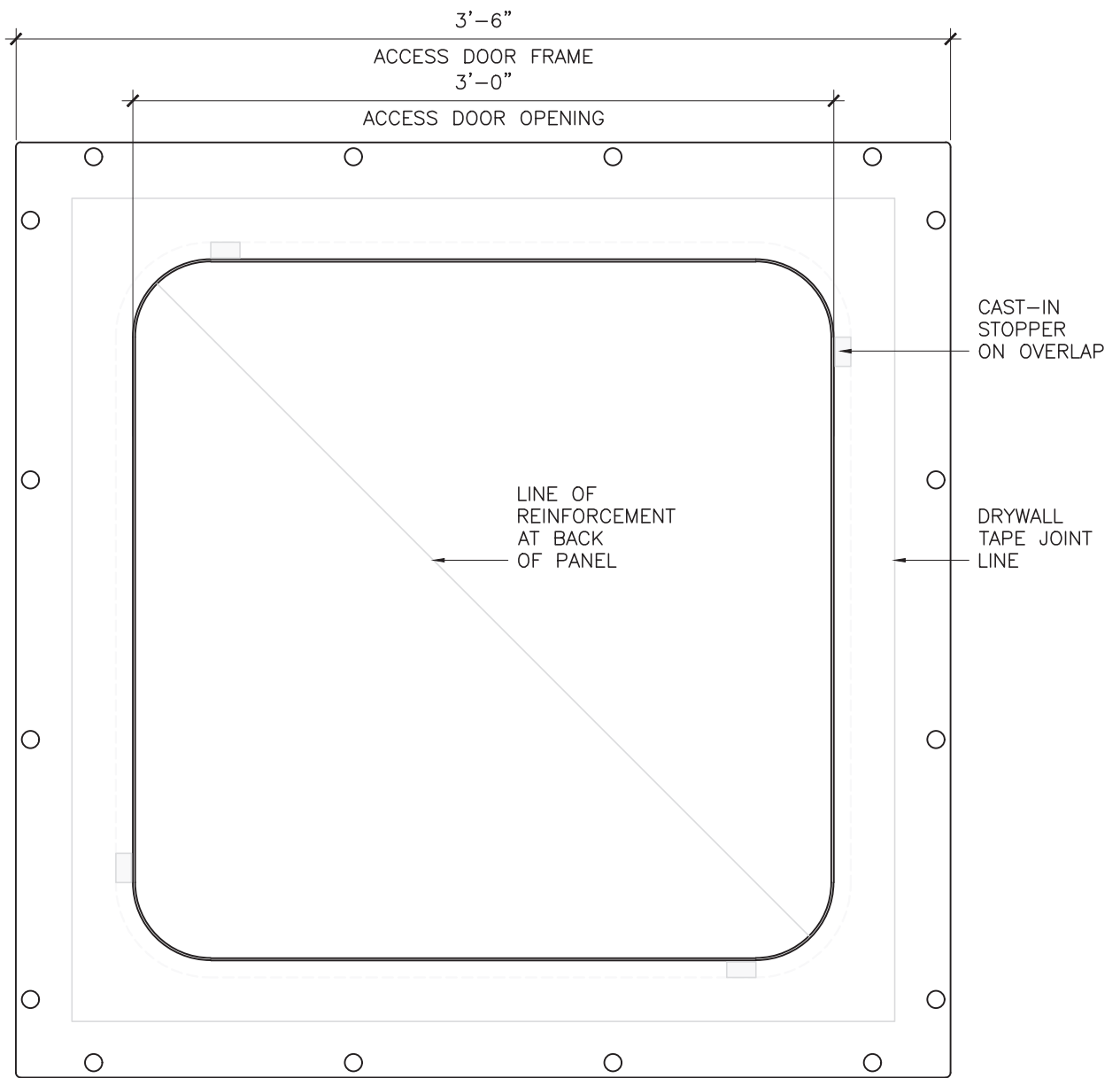

**FOR MORE INFORMATION REFER TO STEALTH
SHOP DRAWING AP-DR3636**

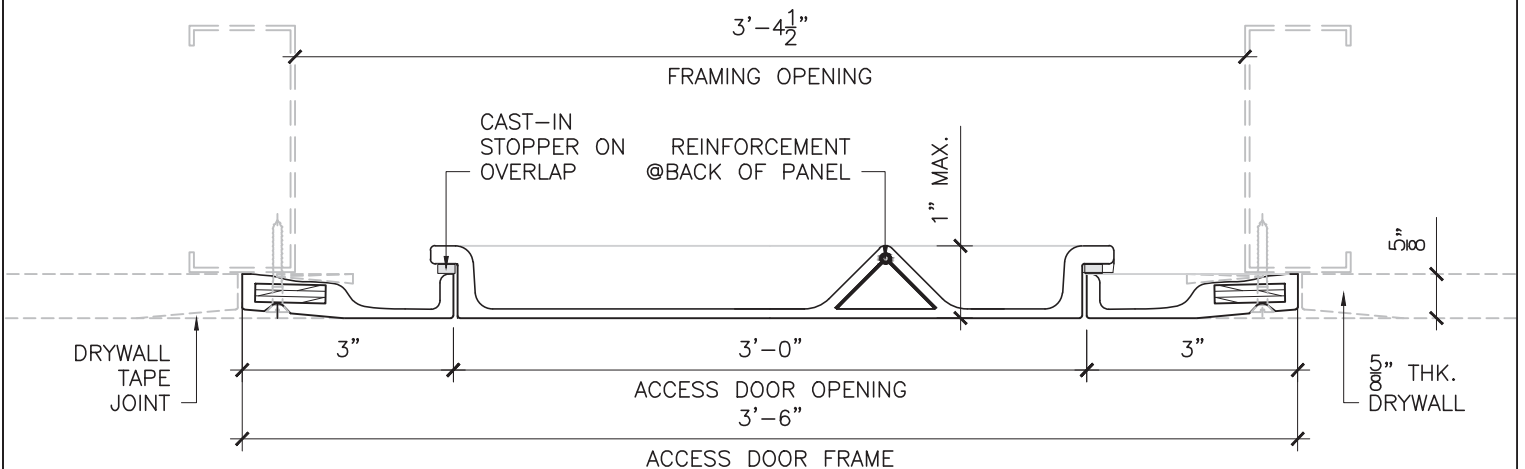

HEAD OFFICE:
1055 LEISCZ'S BRIDGE RD. TOLL: 1(800) 872.5625
LEESPORT, PA 19533 WWW.STEALTHPANELS.COM

SIMPLIFIED PLAN & SECTION
GFRG ACCESS PANEL
DROP IN
RADIUS DOOR CORNERS

DATE: OCT 11/18

SCALE: NTS

DWN.: ML

CHK.:

DWG: **AP-DR3636**

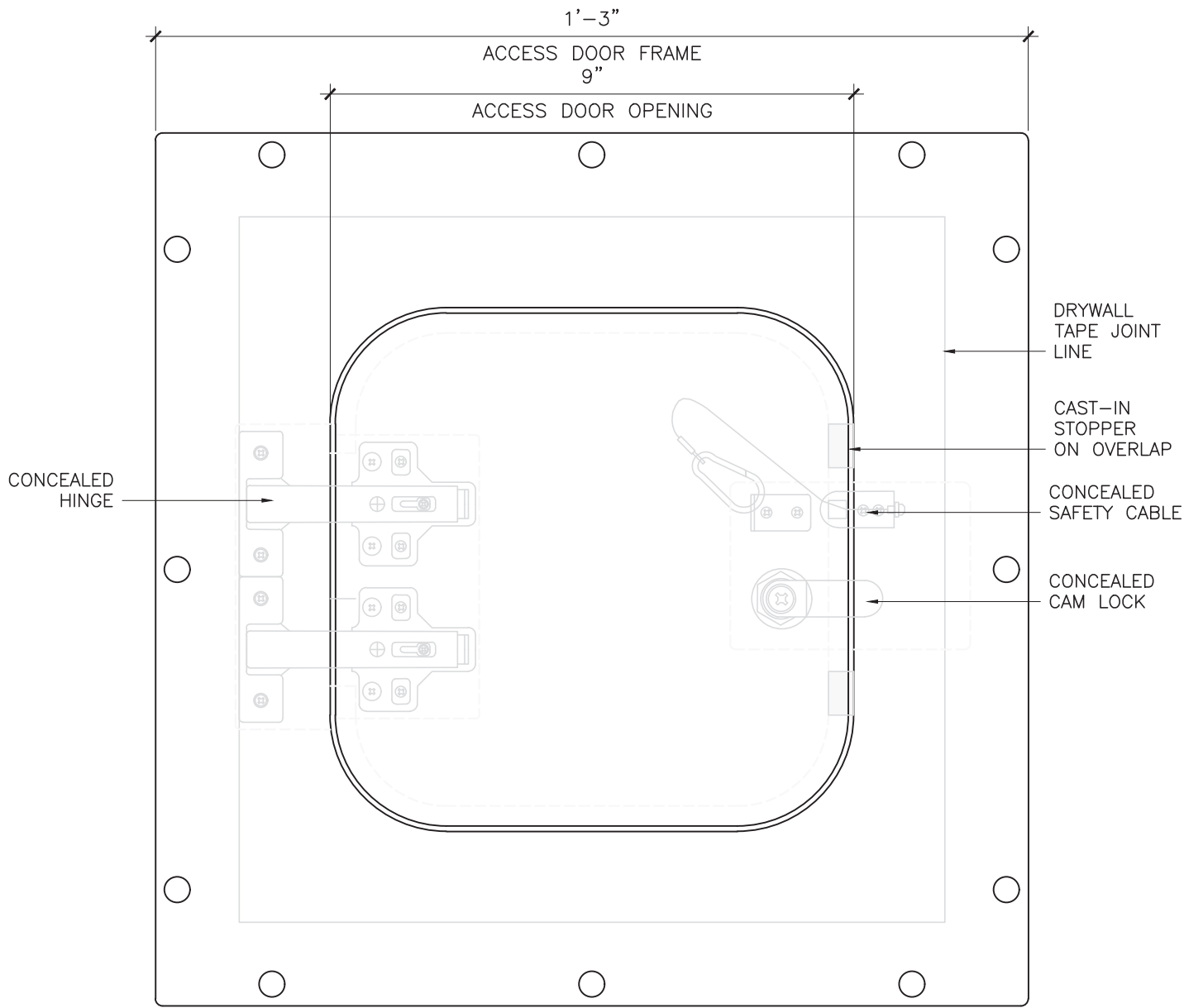

FOR MORE INFORMATION REFER TO STEALTH SHOP DRAWING AP-HRK0909

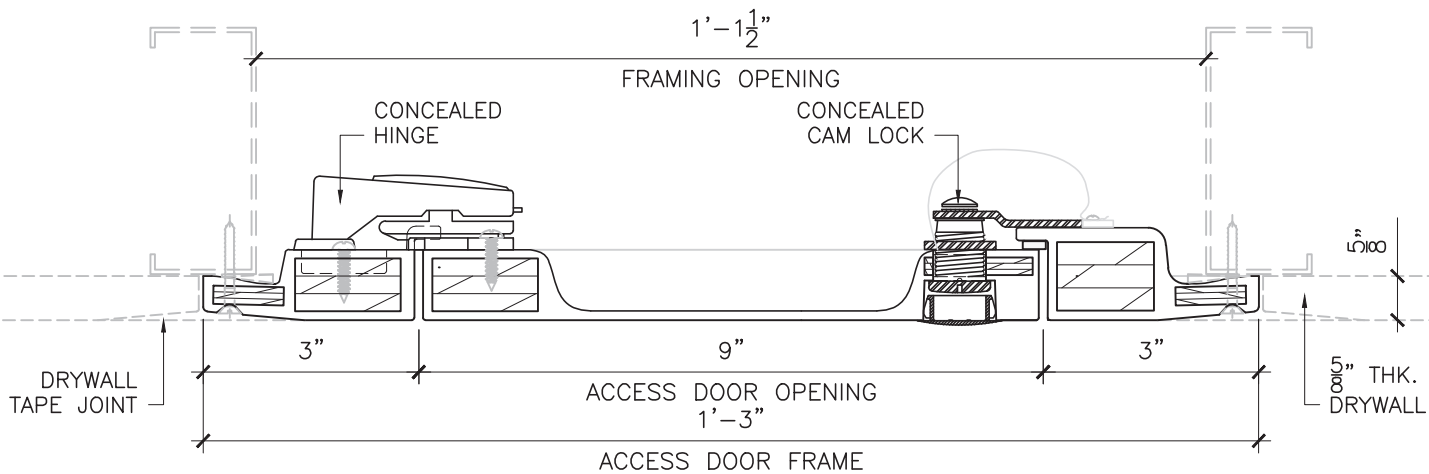

HEAD OFFICE:
1055 LEISCZ'S BRIDGE RD. TOLL: 1(800) 872.5625
LEESPORT, PA 19533 WWW.STEALTHPANELS.COM

SIMPLIFIED PLAN & SECTION
GFRG ACCESS PANEL
KEY-LATCH
RADIUS DOOR CORNERS

DATE: NOV 27/18

SCALE: NTS

DWN.: OT

CHK.:

DWG: **AP-HRK0909**

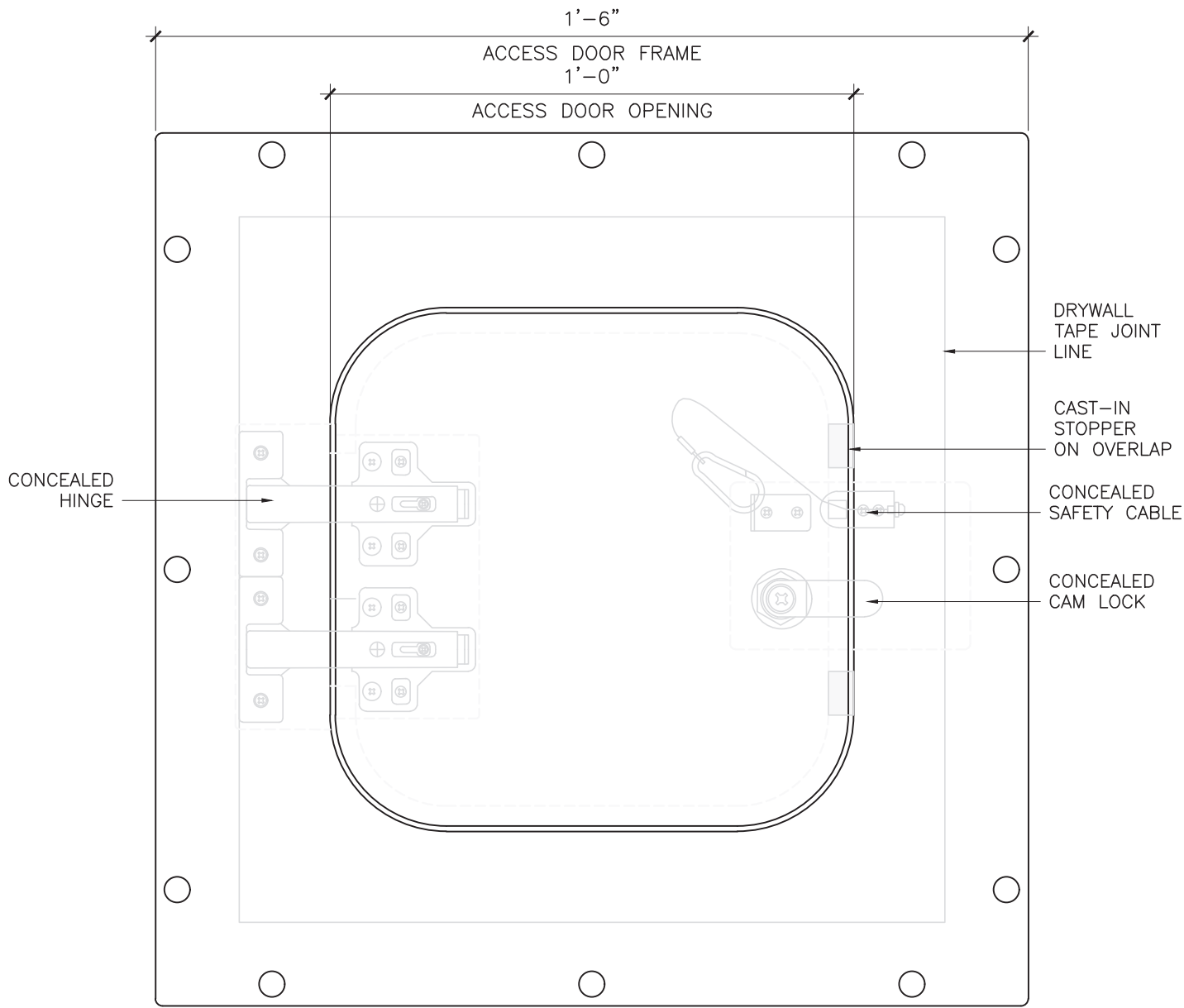

FOR MORE INFORMATION REFER TO STEALTH SHOP DRAWING AP-HRK1212

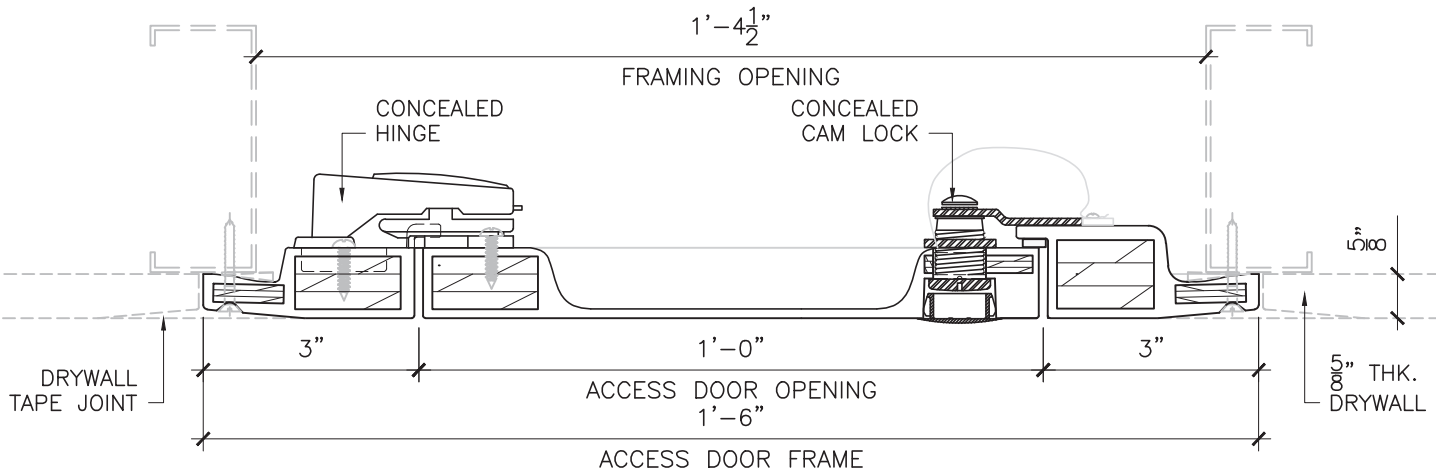

HEAD OFFICE:
1055 LEISCZ'S BRIDGE RD. TOLL: 1(800) 872.5625
LEESPORT, PA 19533 WWW.STEALTHPANELS.COM

SIMPLIFIED PLAN & SECTION
GFRG ACCESS PANEL
KEY-LATCH
RADIUS DOOR CORNERS

DATE: NOV 27/18

SCALE: NTS

DWN.: OT

CHK.:

DWG: **AP-HRK1212**

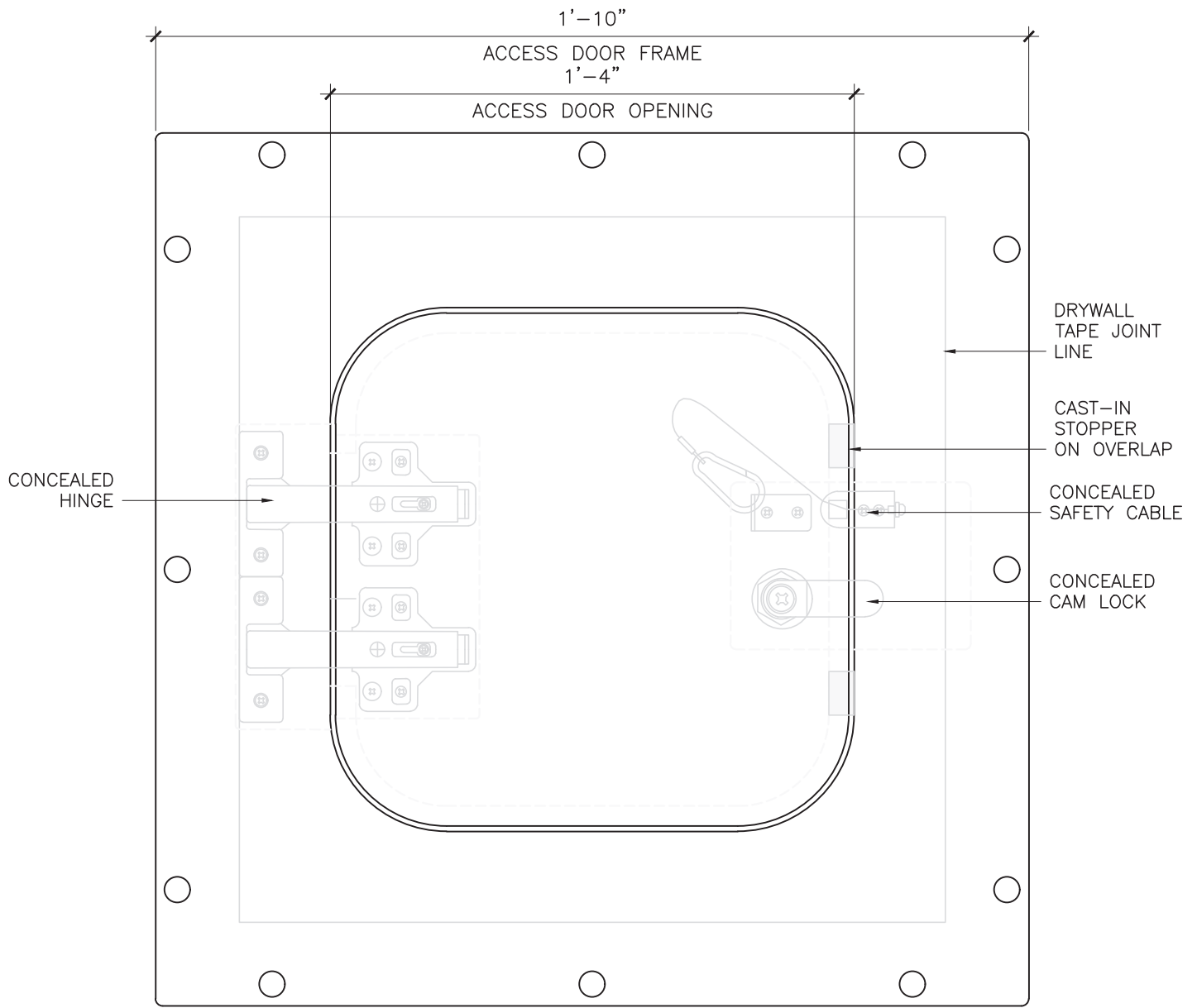

**FOR MORE INFORMATION REFER TO STEALTH
SHOP DRAWING AP-HRK1616**

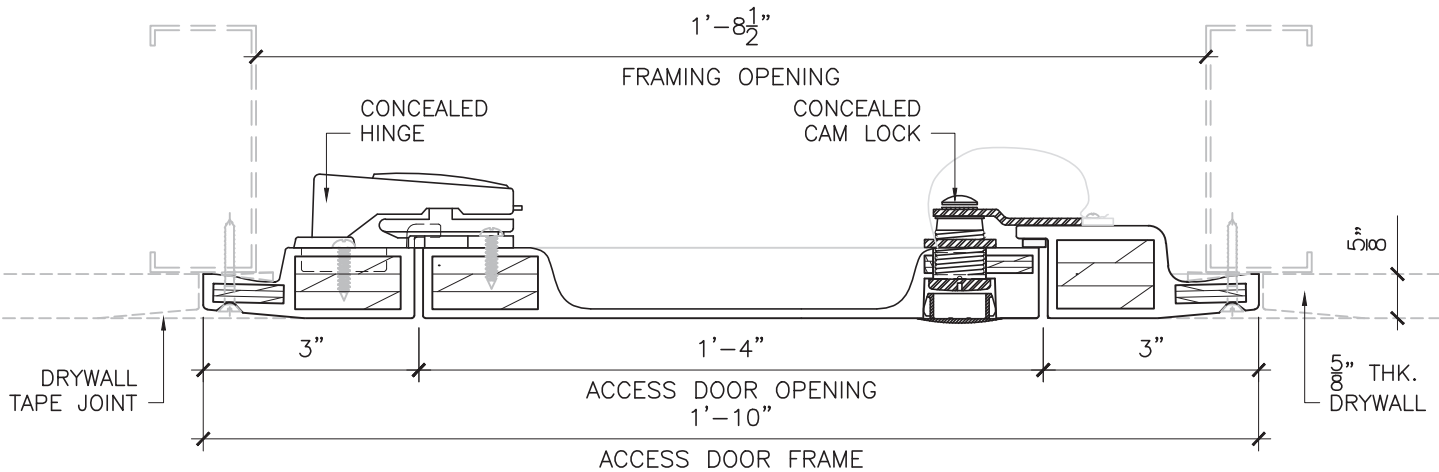

HEAD OFFICE:
1055 LEISCZ'S BRIDGE RD. TOLL: 1(800) 872.5625
LEESPORT, PA 19533 WWW.STEALTHPANELS.COM

SIMPLIFIED PLAN & SECTION
GFRG ACCESS PANEL
KEY-LATCH
RADIUS DOOR CORNERS

DATE: NOV 27/18

SCALE: NTS

DWN.: OT

CHK.:

DWG: **AP-HRK1616**

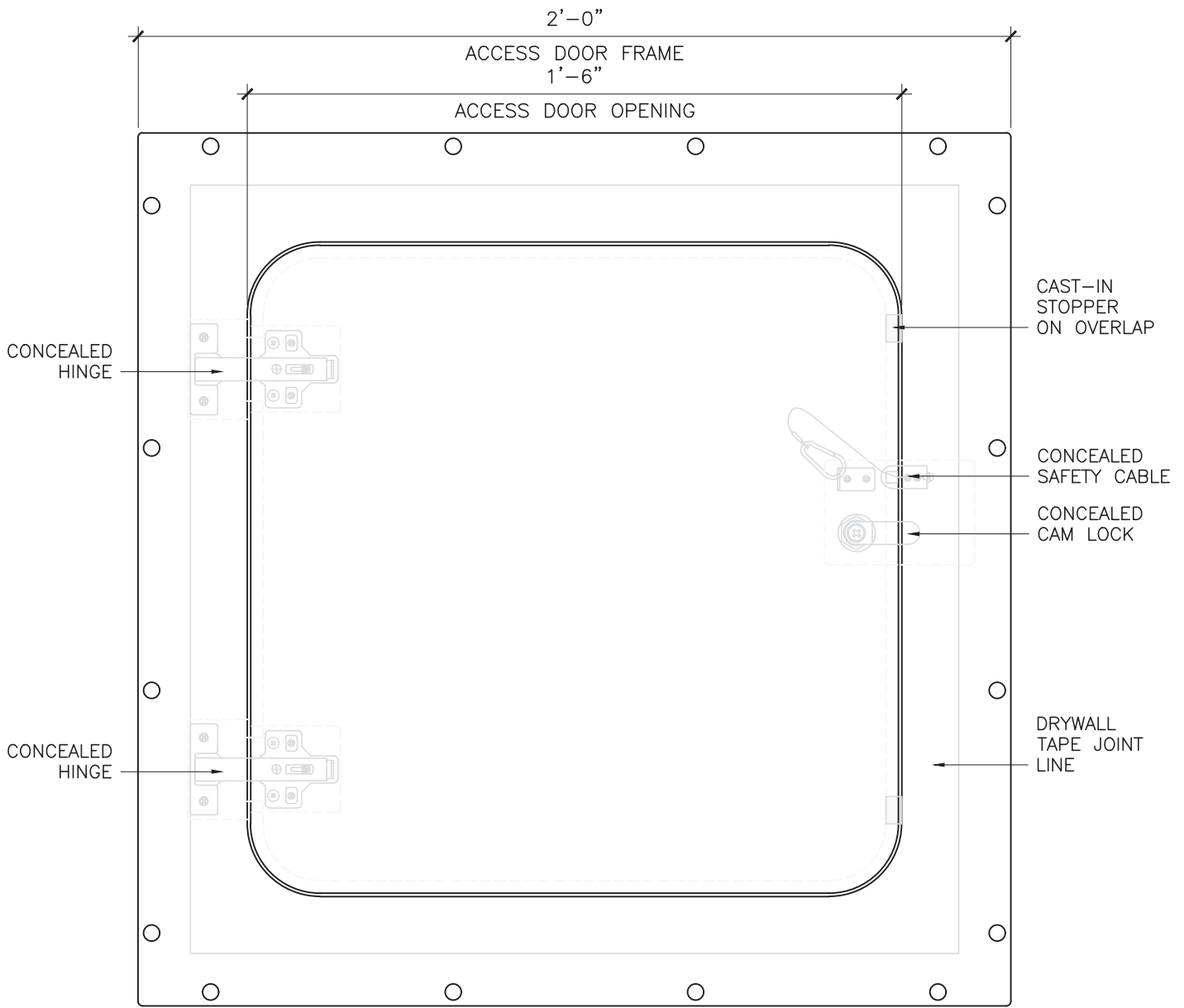

FOR MORE INFORMATION REFER TO STEALTH SHOP DRAWING AP-HRK1818

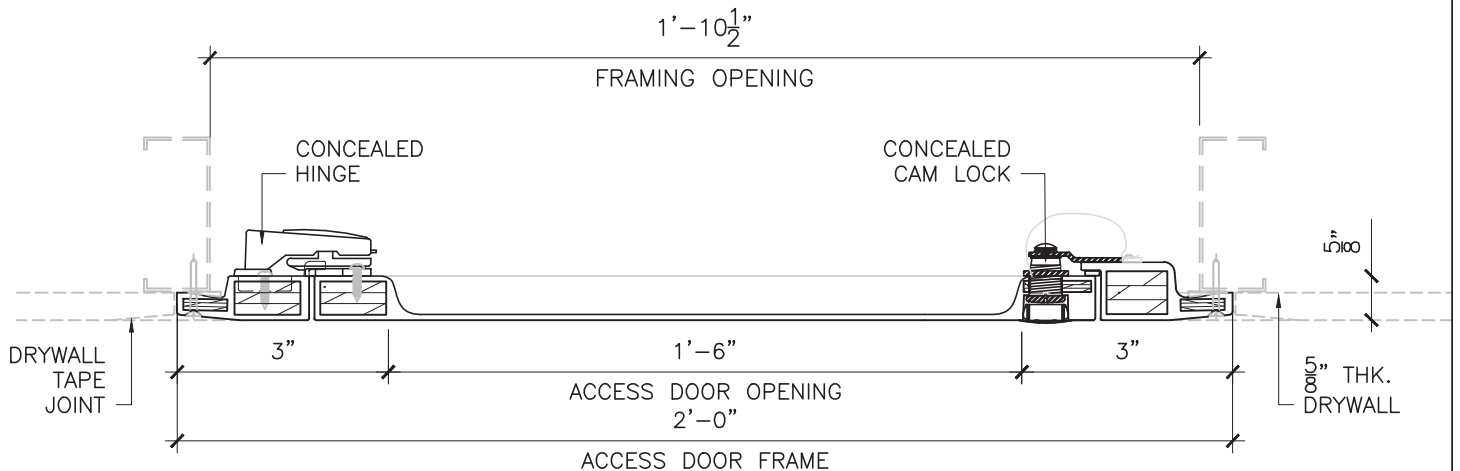

HEAD OFFICE:
1055 LEISCZ'S BRIDGE RD. TOLL: 1(800) 872.5625
LEESPORT, PA 19533 WWW.STEALTHPANELS.COM

SIMPLIFIED PLAN & SECTION
GFRG ACCESS PANEL
KEY-LATCH
RADIUS DOOR CORNERS

DATE: NOV 27/18

SCALE: NTS

DWN.: OT

CHK.:

DWG: **AP-HRK1818**

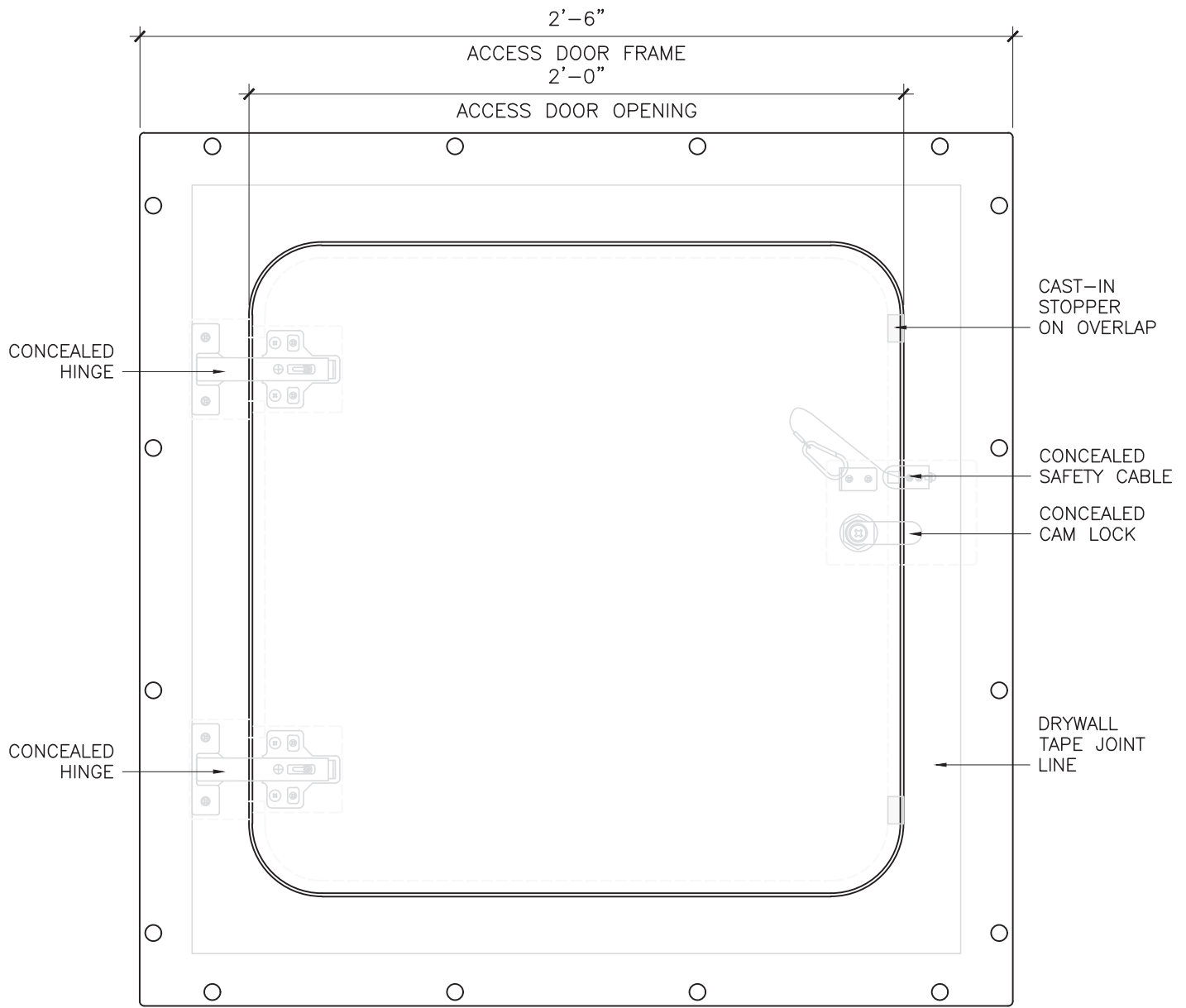

**FOR MORE INFORMATION REFER TO STEALTH
SHOP DRAWING AP-HRK2424**

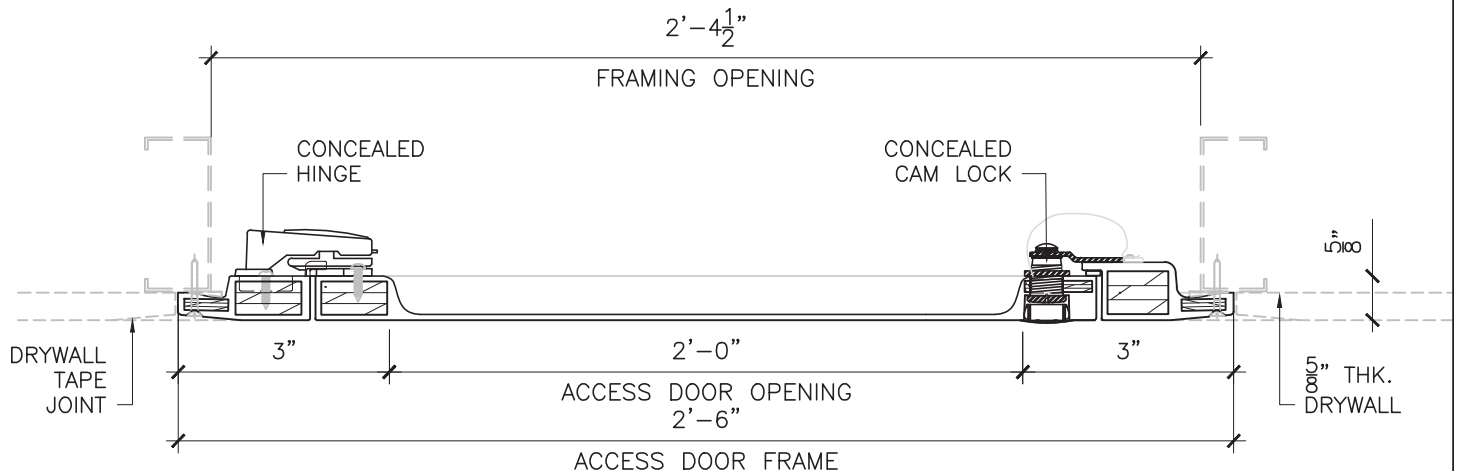

HEAD OFFICE:
1055 LEISCZ'S BRIDGE RD. TOLL: 1(800) 872.5625
LEESPORT, PA 19533 WWW.STEALTHPANELS.COM

SIMPLIFIED PLAN & SECTION
GFRG ACCESS PANEL
KEY-LATCH
RADIUS DOOR CORNERS

DATE: NOV 27/18

SCALE: NTS

DWN.: OT

CHK.:

DWG: **AP-HRK2424**

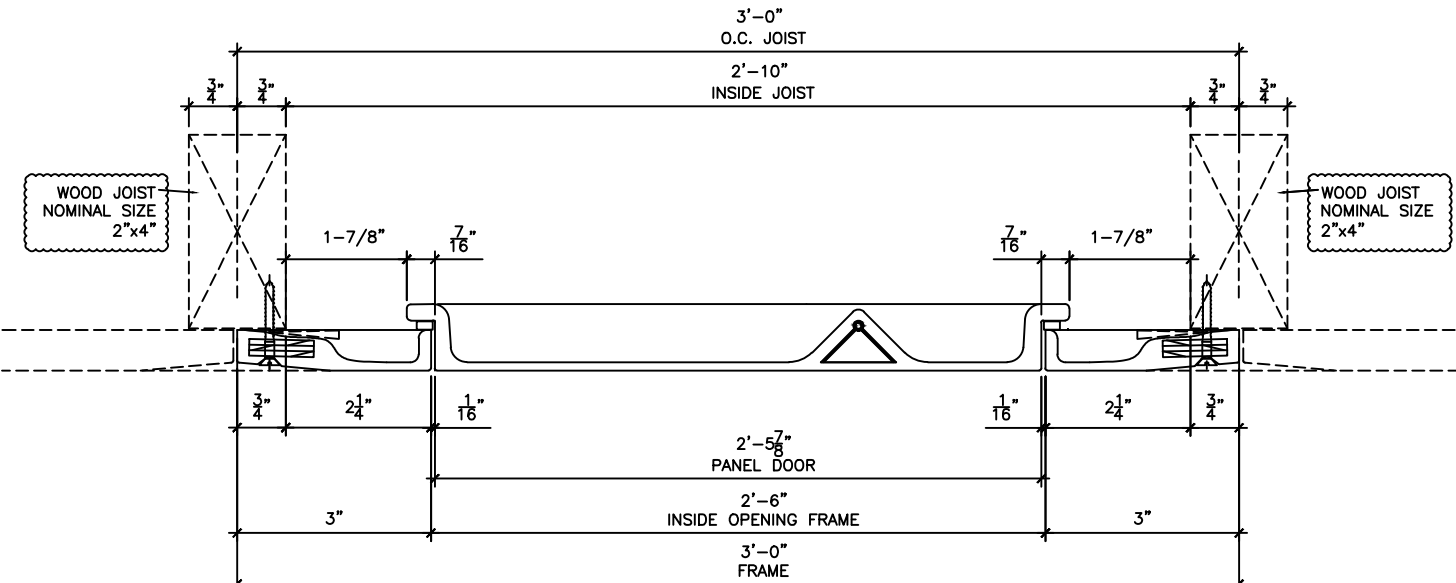
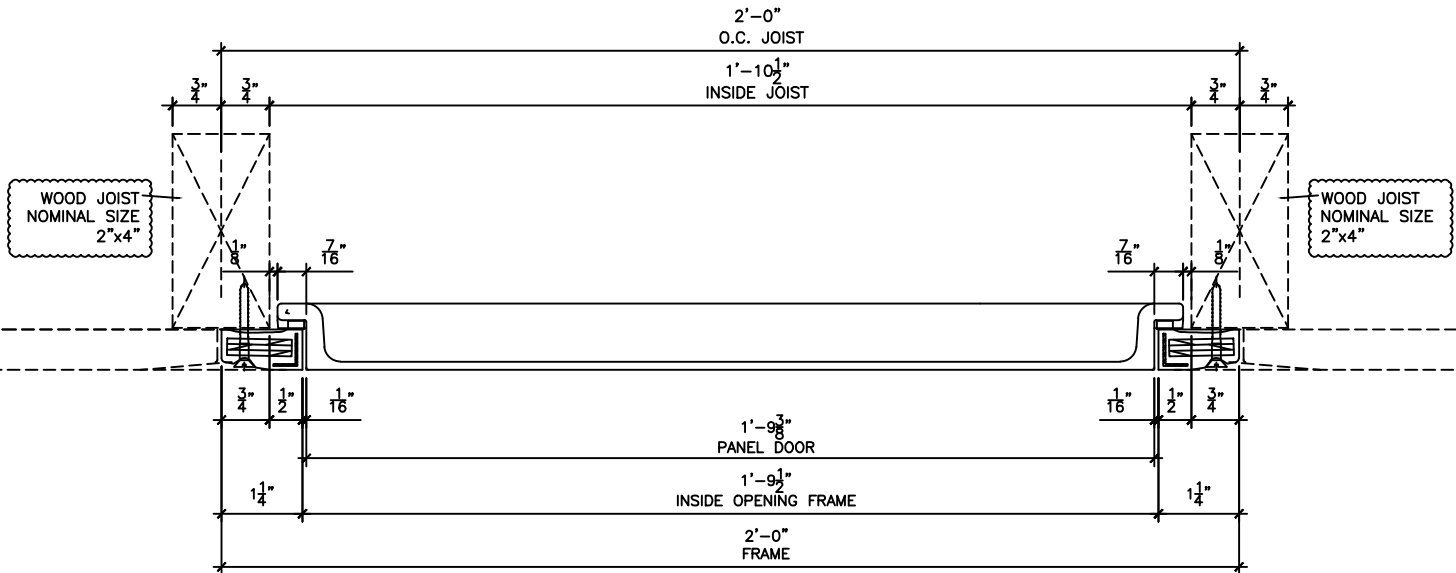
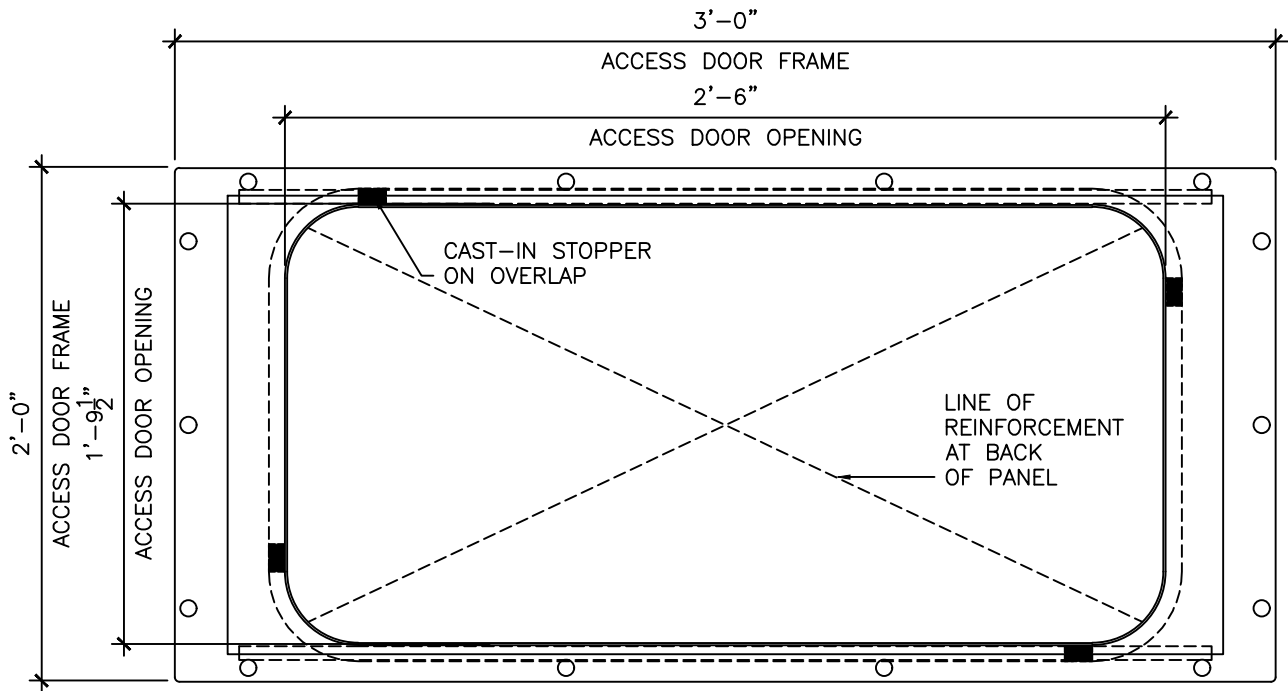

STEALTH
A FORMGLAS | WIND-LOCK. STRATEGIC ALLIANCE

HEAD OFFICE:
1055 LEISCZ'S BRIDGE RD. TOLL: 1(800) 872.5625
LEESPORT, PA 19533 WWW.STEALTHPANELS.COM

SIMPLIFIED PLAN & SECTION
GFRG ACCESS PANEL
DROP IN
RADIUS DOOR CORNERS

DATE: SEP 27 2019 SCALE: NTS
DWN.: ML CHK.:
DWG: **AP-DR2230G**

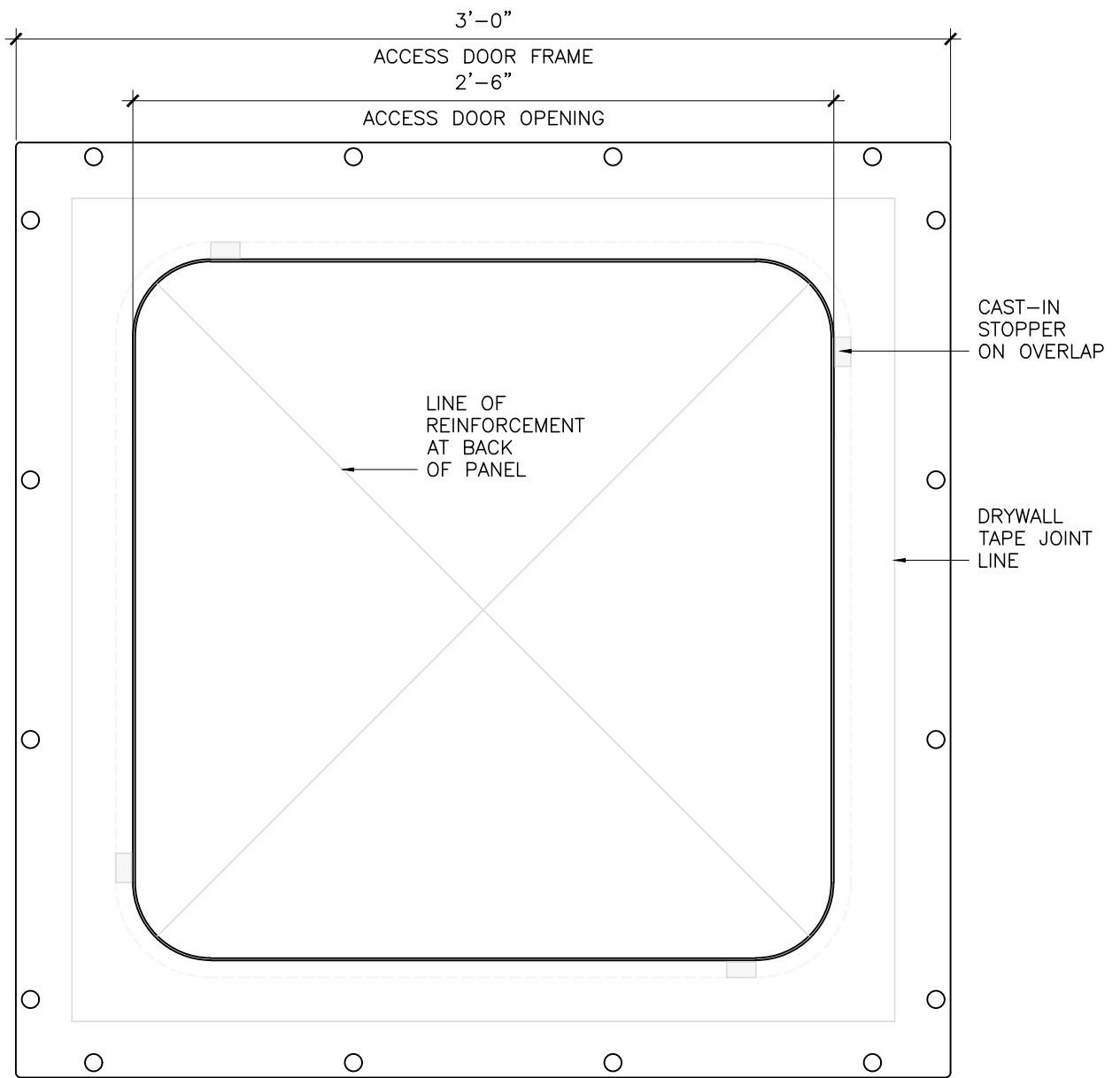

FOR MORE INFORMATION REFER TO STEALTH SHOP DRAWING AP-DR3030G

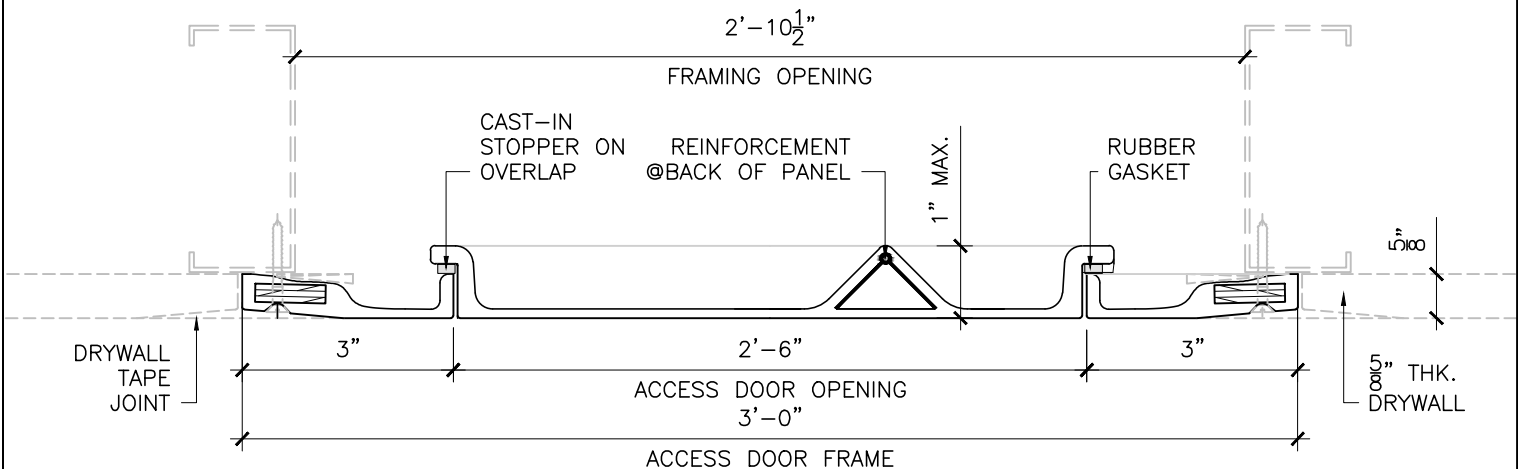

HEAD OFFICE:
1055 LEISCZ'S BRIDGE RD. TOLL: 1(800) 872.5625
LEESPORT, PA 19533 WWW.STEALTHPANELS.COM

SIMPLIFIED PLAN & SECTION
GFRG ACCESS PANEL
DROP IN
RADIUS DOOR CORNERS

DATE: OCT 11/18

SCALE: NTS

DWN.: ML

CHK.:

DWG: **AP-DR3030G**